

Super-Light D-40/E-40

Improvement of the environment and the performance!!



○ **High Intensity UV Radiation**

You never need a darkroom any longer as you can inspect under visible light of 100 Lux. The metal halide lamp emits near UV radiation efficiently and offers twice as strong as Black-Light of mercury type in the same electric power.

○ **Compact body**

Maintenance and installation is easy. And the body being cooled down constantly with the exhaust fan, the temperature of outside of the body is kept at around 35°C (room temperature : 20°C).

○ **Two types of light distribution**

- **D-40** : An uniform UV distribution in broad area (600mm x 250mm).
- **E-40** : Having the advantages of extra high UV intensity with center concentration.

○ **Halation eliminated filter** (US PAT.6.525.315)

New UV transmission filter eliminates the obstacle visible light (Red and Purple) for observation (type-2 filter).

UV RADIATION DISTRIBUTION (Sample data)

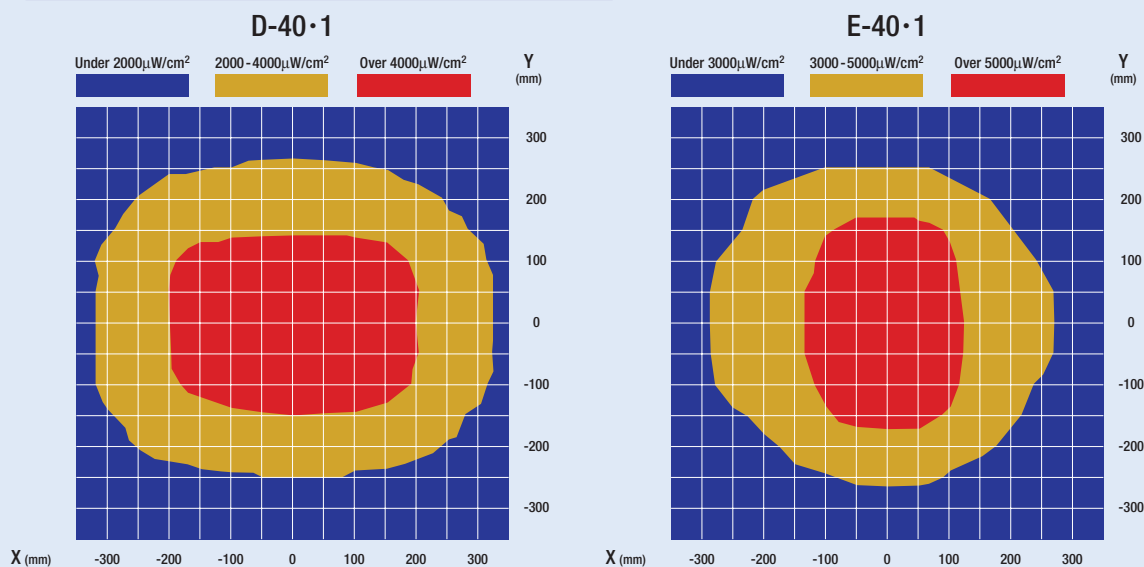

* Typical distribution at 600mm under the filter.

Super-Light D-40/E-40



Super-Light D-40/E-40

CAUTION

- ① Check input power before connecting.
- ② Do not use in the following place;
 - Where the ambient temperature is beyond the limit of 5-40°C.
 - Where it is moist or may be splashed with water and/or any liquid.
 - Which may give a shock or a vibration.
 - Where corrosive and inflammable gas may generate.
- ③ Do not remodel or modify.
- ④ In the electric circuit, do not use a connector to joint.
- ⑤ The circuit can be extended into max.30m, and use 600V heat resistant vinyl electric wire (2.0mm³) or equivalent one.
- ⑥ Protect the knot with an insulating tape as high voltage pulse generates when it starts lighting, do not use injured insulate electric wires. If injured, the electric wire may burn.
- ⑦ Be sure of turning the switch "OFF" before changing the lamp, as the receptacle is charged high voltage. In case the lamp would not light, turn the switch "OFF" immediately and replace with a new one.
- ⑧ Do not look the light source with naked eyes.
- ⑨ Replace the air filter with a new one once a month, in order to prevent from the UV intensity reducing and the lamp life shortening, because of dirty of the reflector or the lamp.
- ⑩ Replace the reflector with a new one once a year.

DIMENSION (D40/E40)

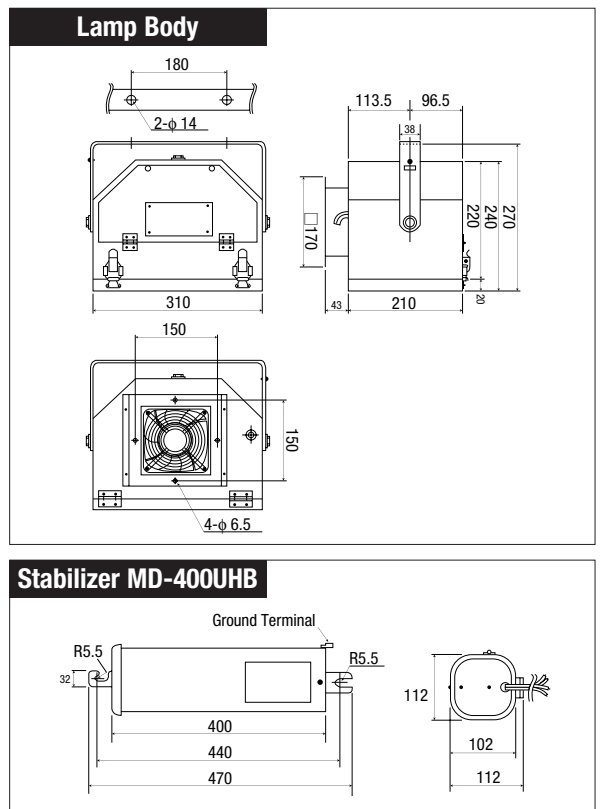

SPECIFICATION

Model	D-40		E-40	
	D-40 · 1	D-40 · 2	E-40 · 1	E-40 · 2
Filter	Combination filter			
UV filter	○	○	○	○
Protect filter	○	-	○	-
Halation-cut filter	-	○	-	○
UV Radiation Intensity (600mm under the filter)	>4200 μw/cm ²	>3900 μw/cm ²	>6000 μw/cm ²	>5500 μw/cm ²
Distribution Reference	A uniform distribution		At its center of distribution	
Power requirement	AC200V/220V ± 6% 50 or 60Hz			
Power consumption	420VA			
Lamp/Lamp life	400W metal halide lamp / about 1500hours			
Times to be steady state	4 minutes			
Main wavelength	Near UV365nm (UV-A)			
Lamp body dimension	310W x 253D x 270Hmm			
Lamp body weight	8.5kg		7.1kg	
Stabilizer dimension	400L x 112W x 112Hmm			
Stabilizer weight	13kg			

☞ All specifications and designing are subject to change without notice.

Integrated supplier of Non-Destructive Testing and Marking



MARKTEC Corporation

Head Office 17-35, Omori Nishi 4-chome, Ota-ku, Tokyo 143-0015 Japan
 Tel: +81-3-3762-4453 Fax: +81-3-3764-4337
 URL: <http://www.marktec.co.jp>

Service Center (East) Tel: +81-3-3765-1712 Fax: +81-3-3768-3958
(West) Tel: +81-6-4861-3700 Fax: +81-6-4861-3702
Narita Plant Tel: +81-476-49-3160 Fax: +81-476-49-3181